

Highest Standards in Weighing Efficiency



Easy Operation

Fast, interactive, and easy to use: the 12.1" touchscreen with LED backlight technology makes weighing products and printing price labels extremely easy, meaning customers can be served quickly and efficiently.



Wide Range of Printer Units

The PC hanging scale UC-HWT-M is available with optional printer units for tickets and labels. The optional 3" label printer is perfect for printing certificates of origin and practical preparation tips.



Exceptional Legibility

All price and weighing information is clear and easy to read in even the poorest lighting conditions. The high-quality customer display with LED backlight technology ensures that there are no misunderstandings with customers.



High Energy Efficiency

Better contrast and brightness with lower power consumption: the UC-HWT-M touchscreen and customer display are extremely energy efficient thanks to their customizable energy saving mode.



UC-HWT-M

High-end PC hanging scale with touchscreen control

The PC hanging scale UC-HWT-M is the perfect choice for companies looking for a high-performance hanging scale with sufficient power reserves for the most demanding applications. The robust stainless steel housing consistently protects the scale's electronics and printer unit against spills, acids, salts, and fats, meaning the UC-HWT-M is perfect for use with moist or juicy products such as fish, seafood, fruit, and vegetables. The high-quality 5.7" customer display with LED backlight technology ensures that weight and price information can be easily read by customers in even the poorest lighting conditions.

- **Compact hanging design – more space for presenting products**
- **Robust and hard-wearing – ideal for moist and juicy products**
- **High-performance processor – for the most demanding applications at the point of sale**
- **Functional design – simple and easy to clean**

For the Most Stringent Demands

The UC Evo Max Line is the METTLER TOLEDO PC scale family for the most stringent demands. The UC Evo Max Line can be used for a wide variety of fresh food ranges and also supports CPU-intensive applications, such as multi-media sales promotions at the point of sale. The UC Evo Max Line impresses with its exceptional network capability and capacity to support external applications.

Technical Data

UC-HWT-M

Touchscreen

- 12.1" (30.7 cm) touch-sensitive screen
- Touchscreen with LED backlight technology
- Screen resolution: 800 x 600 pixels

Customer Screen

- 5.7" (14.5 cm) screen
- Screen with LED backlight technology
- Screen resolution: 640 x 480 pixels

Printer Options

- 2" (54 mm) ticket printer
- 2" (54 mm) linerless printer, optional
- 3" (72 mm) label printer, optional
- Printing speed: up to 125 millimeters/second
- Print resolution: 8 dots/millimeter (200 dpi)
- Logos printed on ticket or label
- Printing of upper and lower case characters
- Choice of 101 print fonts
- Customizable labels

Data Storage

- 250 GB hard drive
- SSD (optional)
- 2 GB RAM
- 4 GB RAM (optional)

Interfaces and Protocols

- TCP/IP Ethernet interface (10/100)
- 1 x RS232 serial interface
- 1 x RJ11 interface for controlling the cash register drawer
- 2 x USB 2.0 connections
- Integrated wireless solution for wireless data transmission according to according to IEEE 802.11b/g/n standard (optional)

Remote Maintenance and Data Communication

- InTouchSM Remote Services
- FTP (File Transfer Protocol)
- VNC (Virtual Network Computing)

Operating System

- Windows Embedded Standard 7
- Linux (optional)

Housing Colors

- Silver

Weighing range*	6 kg	15 kg	6 kg/15 kg
Graduation	2 g	5 g	2 g/5 g
Minimum capacity**	40 g	100 g	40 g

* EC: Printout under minimum capacity possible, but not with price marking.
Tare adjustment across the entire weighing range, automatic zeroing.

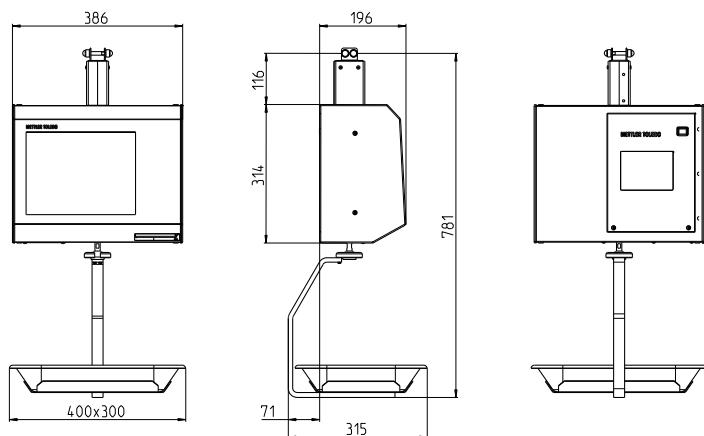

Further Information

For additional details about the features of the UC3 software for METTLER TOLEDO PC-based scales, as well as the optional METTLER TOLEDO applications, please refer to the relevant application sheets.



ISO 9001 quality management certification
ISO 14001 environmental management certification
Internet: <http://www.mt.com>
Worldwide service

Subject to technical changes.
© 09/2011 Mettler-Toledo AG
Printed in Germany 22022897
Global MarCom Switzerland

www.mt.com/retail

Further information

